

SINGLE/DUAL SERIES

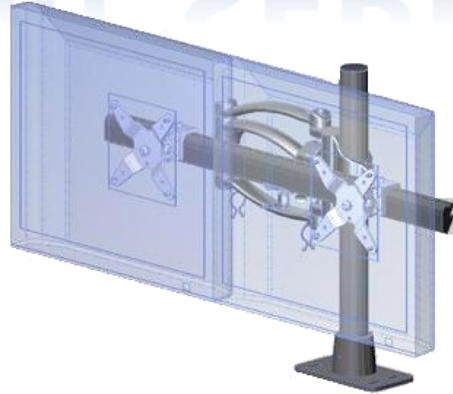

MODEL NUMBER
200-F16-B01



MODEL NUMBER
200-F16-B02

Product Highlights

- Mounts 1 to 2 monitors quickly and cost effectively.
- “Quick Release” pivot mounts.
- “Tool-less” design.
- Arm nests flush without interference in back-to-back situations.
- Quick set-up, installation and adjustment.
- Cable management system.

Product Specifications

- Pivots 20° up/10° down for each monitor
- 75mm and 100mm VESA® compatible
- Holds monitors up to 25 lbs. each
- Lifetime Warranty

Product Options

- Black or Silver
- 16" or 28" vertical poles
- Multiple mounting interfaces
- Tamper-proof pivot for monitor security available



MODEL NUMBER
200-F28-B11

Ergotech Group, Inc
877-523-2767
8 Westchester Plaza, Elmsford, NY 10523
sales@ergotechgroup.com
www.ergotechgroup.com

ERGOTECH
Innovative Mounting Solutions